

SUCTION BASKETS WITH FLAP

SAUGKÖRBE MIT KLAPPE

TYPE/TYP: NP10 DN50-1200

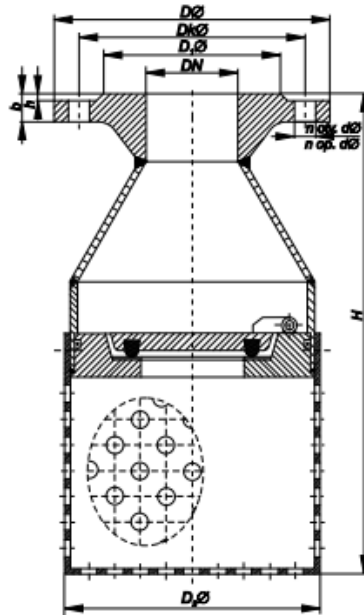

DN	Dø	Dkø	D1ø	b	dø	n	h	D2ø	H	m(kg)
50	165	125	102	18	18	4	3	95	242	9
65	185	145	122	18	18	4	3	130	290	12
80	200	160	138	20	18	4	3	145	305	17
100	220	180	158	20	18	8	3	190	340	25
125	250	210	188	22	18	8	3	220	400	37
150	285	240	212	22	22	8	3	285	475	55
200	340	295	268	24	22	8	3	345	600	86
250	395	350	320	26	22	12	3	410	675	134
300	445	400	370	26	22	12	4	470	745	180
350	505	460	430	26	22	16	4	505	785	245
400	565	515	482	26	26	16	4	725	900	350
450	640	585	532	28	26	16	4	830	1025	450
500	670	620	585	28	26	20	4	910	1125	555
600	780	725	685	28	30	20	5	1020	1255	752
700	895	840	800	30	30	24	5	1170	1410	1005
800	1015	950	905	32	33	24	5	1300	1550	1252
900	1115	1050	1005	34	33	28	5	1450	1690	1645
1000	1230	1160	1110	34	36	28	5	1450	1690	1670
1100	1340	1270	1220	36	36	32	5	1560	1750	1750
1200	1455	1380	1330	38	39	32	5	1600	1750	1970

SUCTION BASKETS WITH FLAP

SAUGKÖRBE MIT KLAPPE

TYPE/TYP: NP16 DN50-1200

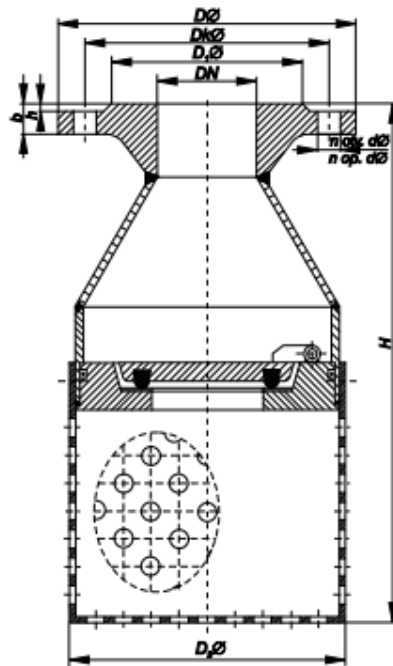

DN	Dø	Dkø	D,ø	b	dø	n	h	D,ø	H	m(kg)
50	165	125	102	18	18	4	3	95	242	9
65	185	145	122	18	18	4	3	130	290	12
80	200	160	138	20	18	8	3	145	305	17
100	220	180	158	20	18	8	3	190	340	25
125	250	210	188	22	18	8	3	220	400	37
150	285	240	212	22	22	8	3	285	475	55
200	340	295	268	24	22	12	3	345	600	86
250	405	355	320	26	22	12	3	410	675	139
300	460	410	378	26	26	12	4	470	745	185
350	520	470	438	26	26	16	4	505	785	253
400	580	525	490	26	30	16	4	725	900	357
450	640	585	550	28	30	20	4	830	1025	457
500	715	650	610	28	33	20	4	910	1125	580
600	840	770	725	28	36	20	5	1020	1255	795
700	910	840	795	30	36	24	5	1170	1410	1017
800	1025	950	900	32	39	24	5	1300	1550	1265
900	1125	1050	1000	34	39	28	5	1450	1690	1660
1000	1255	1170	1115	34	42	28	5	1450	1690	1685
1100	1355	1270	1230	36	42	32	5	1560	1750	1760
1200	1485	1390	1330	38	48	32	5	1600	1750	1995