

TANK TRUCK FOR FUEL

1. DRAWING

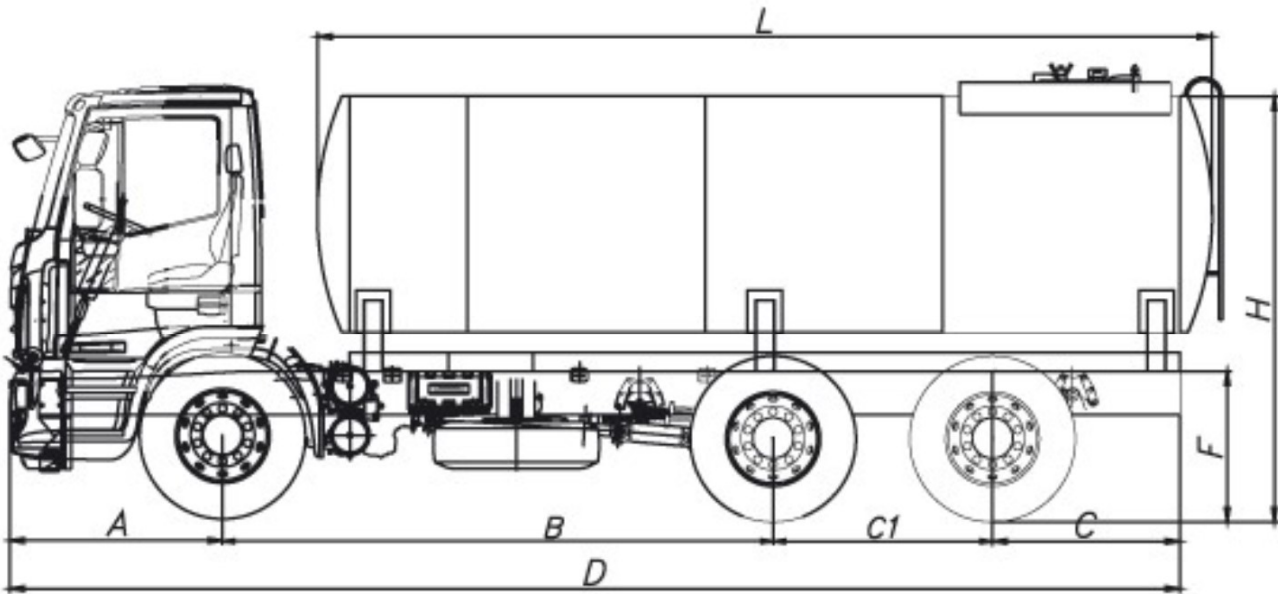

2. MEASURES

Tip (Type)			ACG	
Fuel tank volume	Cylindrical/Eliptical	m ³	min 4	max 16
Fuel pump	Capacity	lit/min	min 80	max 330
	Pressure	bar	min 0.9	max 2
Dimensions	A	mm	min 1.300	max 1.600
	B	mm	min 2.500	max 4.200+1.350
	C	mm	min 850	max 1.800
	D	mm	min 7.500	max 10.500
	E	mm	min 1.000	max 2.500
	H	mm	min 2.500	max 3.400
	L	mm	min 1.500	max 6.000
	F	mm	min 900	max 1.100
	Width	mm	min 1.400	max 2.200
Weight of superstructure		kg	min 500	max 2.000
Weight of nonloaded superstructure + basis vehicle		kg	min 3.000	max 12.000
Payload		kg	min 4.000	max 16.000
Recommended chasis	Totality allowed weight	kg	min 7.000	max 28.000
	Engine power	kw (hp)	min 95 (130)	max 200 (270)